

FINAL REPORT

ADB



Asian Development Bank
National Capital Region Planning Board

Capacity Development of the
National Capital Region Planning Board
Package 2 Component B
TA No. 7055-IND

Volume V-A6: Initial Environmental Examination DPR for Flyover at Mohan Nagar Junction in Ghaziabad

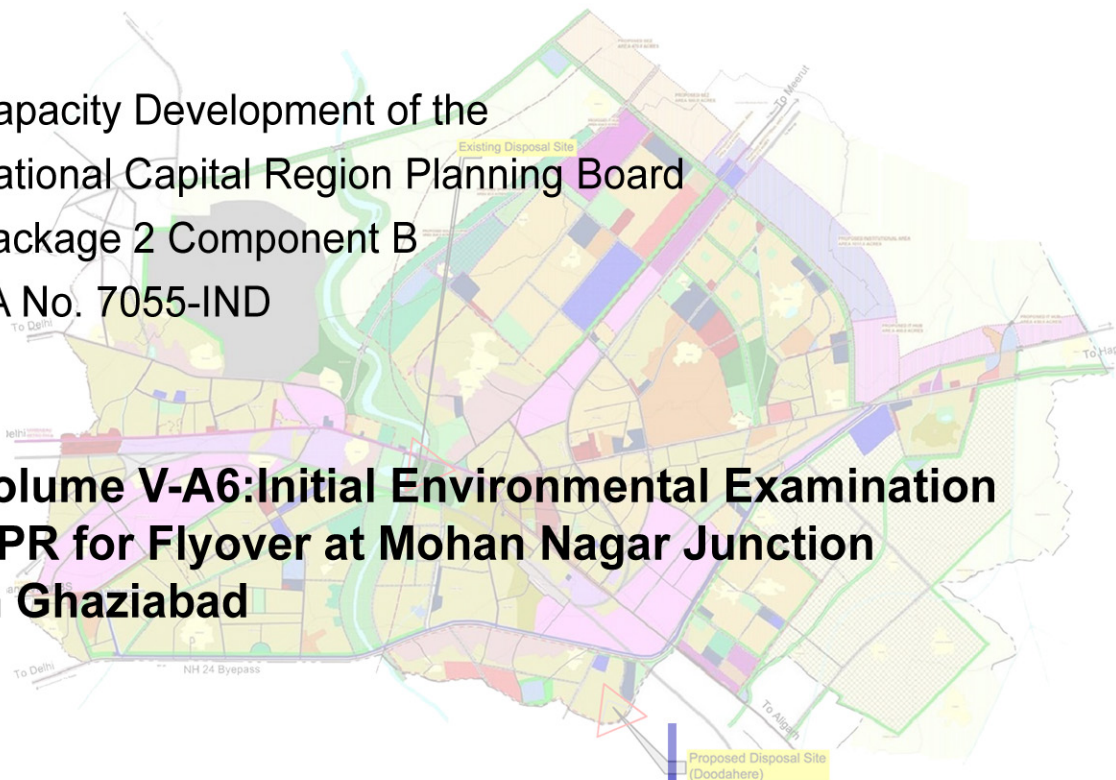

WilburSmith
ASSOCIATES

July 2010

NCR Planning Board
Asian Development Bank

Capacity Development of the National Capital Region Planning Board (NCRPB) – Component B (TA No. 7055-IND)

FINAL REPORT

Volume V-A6: DPR for Flyover at Mohan Nagar Junction in
Ghaziabad

Initial Environmental Examination Report

July 2010



Abbreviations

ADB	:	Asian Development Bank
BOD	:	Biochemical Oxygen Demand
CC	:	Construction Contractor
CGWA	:	Central Ground Water Authority
CGWB	:	Central Ground Water Board
CMA	:	Counter Magnet Areas
COD	:	Chemical Oxygen Demand
DFR	:	Draft Final Report
DPR	:	Detailed Project Report
EAC	:	Environmental Appraisal Committee
EC	:	Environmental Clearance
EIA	:	Environmental Impact Assessment
EMP	:	Environmental Management Plan
ESMC	:	Environmental & Social Management Cell of NCRPB
ESMS	:	Environmental & Social Management System of NCRPB
GDA	:	Ghaziabad Development Authority
GNN	:	Ghaziabad Nagar Nigam
GoH	:	Government of Haryana
GoI	:	Government of India
GoUP	:	Government of Uttar Pradesh
IA	:	Implementing Agencies
IEE	:	Initial Environmental Examination
IPT	:	Intermediate Public Transport
IRC	:	Indian Road Congress
km	:	Kilometer
KMPH	:	Kilometer per Hour
LA	:	Land Acquisition
LCV	:	Light Commercial Vehicle
LPCD	:	Liters per capita per day
MLD	:	Million Liters per Day
MoRTH	:	Ministry of Road Transport and Highways
MoEF	:	Ministry of Environment & Forests
NCR	:	National Capital Region
NCRPB	:	National Capital Region Planning Board
NCT	:	National Capital Territory
NGO	:	Non-governmental Organizations
NH	:	National Highway
O & M	:	Operation and Maintenance
PCU	:	Passenger Car Unit
PSC	:	Pre-stressed Concrete
R & R	:	Resettlement and Rehabilitations
RSPM	:	Respirable Suspected Particulate Matter

ROW	:	Right of Way
RCC	:	Reinforced Cement Concrete
SH	:	State Highway
SPM	:	Suspected Particulate Matter
TA	:	Technical Assistance
UP	:	Uttar Pradesh
UPJN	:	Uttar Pradesh Jal Nigam
UPSIDC	:	Uttar Pradesh State Industrial Development Corporation

Contents

1. INTRODUCTION.....	1
A. BACKGROUND	1
2. POLICY & LEGAL FRAMEWORK.....	3
A. EXTENT OF IEE STUDY	3
B. GOVERNMENT LAW AND POLICIES	3
C. ENVIRONMENTAL AND SOCIAL MANAGEMENT SYSTEM OF NCRPB	4
1. <i>Environmental Policy</i>	4
2. <i>Environmental Assessment Requirements</i>	5
3. DESCRIPTION OF PROJECT	6
A. PROJECT NEED.....	6
B. PROPOSED SUBPROJECT	6
4. DESCRIPTION OF ENVIRONMENT	14
A. PHYSICAL RESOURCES	14
1. <i>Location</i>	14
2. <i>Topography, Soil and Geology</i>	14
3. <i>Climate</i>	16
4. <i>Air Quality</i>	17
5. <i>Surface Water</i>	18
6. <i>Groundwater</i>	18
B. ECOLOGICAL RESOURCES	19
C. ECONOMIC DEVELOPMENT.....	19
1. <i>Land Use</i>	19
2. <i>Industry & Agriculture</i>	20
3. <i>Infrastructure</i>	20
4. <i>Transportation</i>	21
D. SOCIAL AND CULTURAL RESOURCES	21
1. <i>Demography</i>	21
2. <i>Health & Education Facilities</i>	23
3. <i>History Culture and Tourism</i>	24
E. PROFILE OF PROPOSED FLYOVER SITE.....	24
5. ENVIRONMENTAL IMPACTS & MITIGATION MEASURES	26
A. OVERVIEW	26
B. CONSTRUCTION IMPACTS	26
1. <i>Impacts on Physical Resources</i>	27
2. <i>Ecological Resources</i>	29
3. <i>Economic Development</i>	29
4. <i>Social and Cultural Resources</i>	30
C. OPERATION STAGE IMPACTS	31
1. <i>Physical Resources</i>	32
2. <i>Ecological Resources</i>	32
3. <i>Economic Development</i>	32
4. <i>Social and Cultural Resources</i>	33
D. LOCATION AND DESIGN IMPACTS	33
6. INSTITUTIONAL ARRANGEMENTS.....	34
A. INSTITUTIONS INVOLVED	34
7. ENVIRONMENTAL MANAGEMENT PLAN	35
A. ENVIRONMENTAL MANAGEMENT PLAN	35
B. ENVIRONMENTAL MONITORING PLAN	35
8. PUBLIC CONSULTATION AND INFORMATION DISCLOSURE	44

A. PROJECT STAKEHOLDERS.....	44
B. CONSULTATION AND DISCLOSURE.....	44
9. RECOMMENDATION AND CONCLUSION.....	45
A. RECOMMENDATION.....	45
B. CONCLUSION.....	47

List of Tables

Table 2-1: Environmental Category.....	5
Table 3-1: Projected Traffic at Mohan Nagar Junction.....	6
Table 3-2: Details of existing utilities.....	13
Table 4-1: Rainfall Pattern in Ghaziabad (2004-2008).....	16
Table 4-2: Air Pollution Status in Ghaziabad (2008).....	17
Table 4-3: Air Pollution Classification based on Annual Mean Concentration Range ($\mu\text{g}/\text{m}^3$).....	17
Table 4-4: NAAQ Standard – Annual Average Concentration in $\mu\text{g}/\text{m}^3$	18
Table 4-5: Population Growth of Ghaziabad City.....	22
Table 5-1: Construction Method & Materials of Flyover.....	26
Table 7-1: Environmental Management Plan.....	36
Table 7-2: Environmental Monitoring Plan.....	42

List of Figures

Figure 1-1: Regional Setting of Ghaziabad.....	2
Figure 3-1: Location of Proposed Flyover at Mohan Nagar Chowk.....	7
Figure 3-2: Orientation of Proposed Flyover at Mohan Nagar Chowk.....	8
Figure 3-3: Typical cross section of flyover.....	9
Figure 3-4: Plan & Profile of Proposed Flyover.....	10
Figure 4-1: Ghaziabad Base Map.....	15
Figure 4-2: Long-term Annual Rainfall Pattern of Ghaziabad (in millimeter).....	16
Figure 4-3: Average Monthly Temperature (in Degrees Centigrade).....	17
Figure 4-4: Existing Land Use.....	20
Figure 4-5: Occupational Structure.....	23

1. INTRODUCTION

A. Background

1. Ghaziabad City is located in the western part of Uttar Pradesh State sharing the borders with the National Capital Territory Delhi. It is the district headquarters of Ghaziabad District. Owing to its location close to Delhi, and with good connectivity, it is one of the important and fast developing city in the State of Uttar Pradesh and as well as in the National Capital Region. City is well connected with important cities of the state and the country; three National Highways (NH 58, NH 91 and NH 24 - Delhi-Lucknow-Muradabad Road) pass through the City connecting it with Delhi, Meerut, Lucknow, Sikandrabad, Kolkata etc. Besides, it is well connected with its hinterland and surrounding towns by regional and local road network. It is also well connected with railways. Location of Ghaziabad is depicted in **Figure 1-1**.
2. The rapid development of city has also put its infrastructure on tremendous pressure. Due to rapid increase in vehicles and traffic, the road infrastructure is severely affected. The vehicle speed on various roads is decreased significantly, while junctions have become bottle necks free traffic movement. Mohan Nagar Junction (Patel Chowk intersection) on NH 24 is one of the critical locations that carry a high volume of traffic. Based on the traffic analysis carried out, a flyover is proposed at this location.
3. The subproject of construction of Flyover at Mohan Nagar Junction is selected for detailed study and preparation of a model Detailed Project Report under this ADB TA Component B. NCR Planning Board, a statutory body of Ministry of Urban Development, Government of India, is a likely source of funding for the subproject in Ghaziabad.
4. This Initial Environmental Examination (IEE) Report is prepared in accordance with NCRPB Environmental and Social Management System (ESMS) and Policy for project funding.

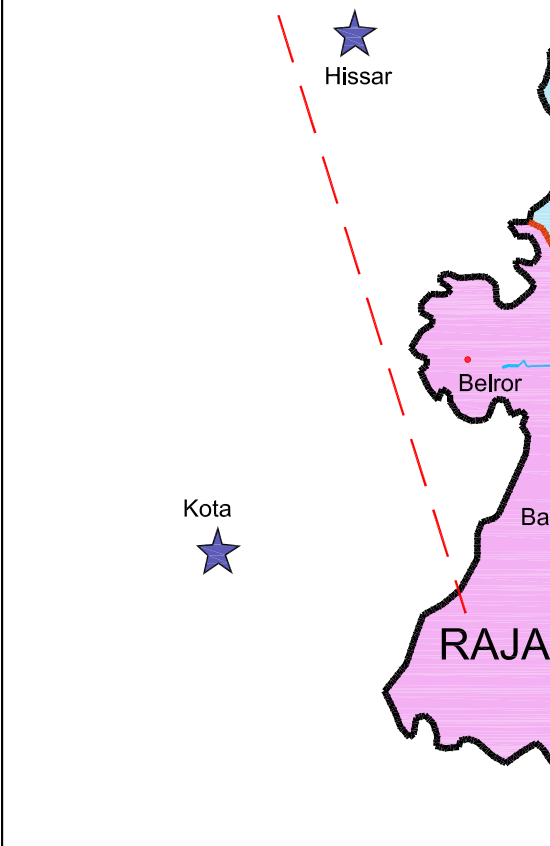
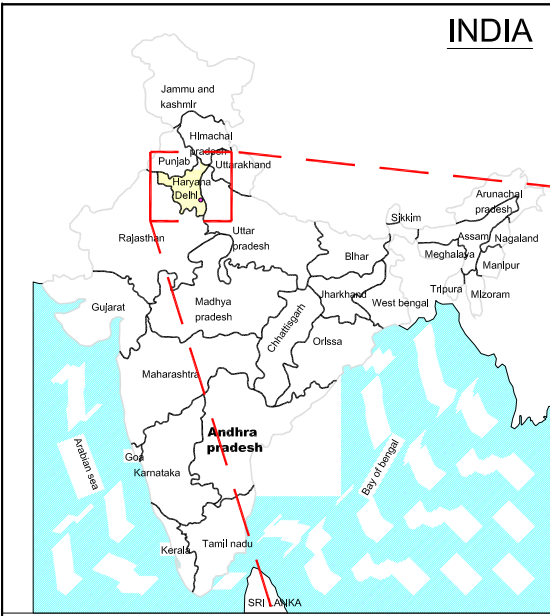

Capacity Development of the NCRPB: Component B (ADB TA 7055-IND)

Regional Setting of Ghaziabad

- Legend**
- NCR
 - State Boundary
 - District Boundary
 - District Hq.
 - Counter Magnet Areas
 - River / Stream

Client:
**Asian Development Bank
 National Capital Region Planning Board**

Consultant:
Wilbur Smith Associates Pvt. Ltd.

Drawn: Roopa	Checked:
Date:	Approved:
Scale: Not to scale	

2. POLICY & LEGAL FRAMEWORK

A. Extent of IEE Study

5. The subproject implementation shall comply with the policies of Government of India (GoI), Government of Uttar Pradesh (GoUP) and procedures/policies of NCRPB. Government regulations and the NCRPB policy require that impacts of the development projects have to be identified at the beginning and mitigation measures be incorporated in the project to reduce those impacts to acceptable levels. This is generally done through the process of environmental impact assessment.

B. Government Law and Policies

6. The GoI EIA Notification of 2006 (replacing the EIA Notification of 1994), sets out the requirement for Environmental Assessment in India. This states that Environmental Clearance (EC) is required for specified activities/projects, and this must be obtained before any construction work or land preparation (except land acquisition) may commence. Projects are categorized as A or B depending on the scale of the project and the nature of its impacts.
7. Category A projects requires EC from the national Ministry of Environment and Forests (MoEF). The proponent is required to provide preliminary details of the project in the prescribed manner with all requisite details, after which an Expert Appraisal Committee (EAC) of the MoEF prepares comprehensive Terms of Reference (ToR) for the EIA study. On completion of the study and review of the report by the EAC, MoEF considers the recommendation of the EAC and provides the EC if appropriate.
8. Category B projects require environmental clearance from the State Environment Impact Assessment Authority (SEIAA). The State level EAC categorizes the project as either B1 (requiring EIA study) or B2 (no EIA study), and prepares ToR for B1 projects within 60 days. On completion of the study and review of the report by the EAC, the SEIAA issues the EC based on the EAC recommendation. The Notification also provides that any project or activity classified as category B will be treated as category A if it is located in whole or in part within 10 km from the boundary of protected areas, notified areas or inter-state or international boundaries.
9. This subproject of construction of flyover does not falls under the ambit of the EIA Notification, and, therefore EC is, thus, not required.

C. Environmental and Social Management System of NCRPB

10. Recognizing the importance of environmental and social issues that can arise in infrastructure projects, NCRPB has formulated an Environmental and Social Management Systems (ESMS) in line with Government and other multilateral agencies like ADB safeguard requirements for Financial Intermediaries (FIs). The ESMS provides an overall management system to NCRPB to identify, assess, and mitigate environmental and social issues that are likely to arise in projects funded by NCRPB. The ESMS outlines the policies, methods of assessments and procedures that will enable NCRPB to ensure that a project that it funds is developed in accordance with ESMS and is adequately protected from associated risks. Implementing Agencies (IAs) will have to comply with the ESMS and Policy.

1. Environmental Policy

11. *Policy Statement.* “National Capital Regional Planning Board (NCRPB) will continually strive to ensure and enhance effective environmental management practices in all its operations”. This is aimed to achieve through:
- Minimizing negative environmental (including health & safety) impacts in its operations and risks to the environment (particularly eco-sensitive areas and culturally important areas) and people who may be affected through formulating and implementing commensurate plans
 - Ensuring that environmental safeguards - defined as requirements of applicable Indian environmental legislation and multilateral / bilateral funding agencies - are being adequately integrated by the project proponent / IA in the planning, design, construction prior to its financing and in its implementation during the operational phase.
 - Ensuring that compliance to all applicable national and local environmental legislation.
 - Encouraging that public and stakeholder consultation be carried out by the project proponent / IA and disclosing the required information in all stages of the project cycle.
 - Integrating environmental risk into its overall internal risk management analysis.
 - Including environmental management considerations in all aspects of operations and interactions with the project proponent / IAs in all stages of the project cycle.
12. This policy statement emphasizes NCRPB's sensitivity, concern and commitment to environmental safeguards. NCRPB will strive to ensure that the projects that it supports meets government policies and as well as of the bilateral/multilateral agencies such as ADB.

2. *Environmental Assessment Requirements*

13. The nature of the assessment required for a project depends on the significance of its likely environmental impacts, which are related to the type and location of the project, the sensitivity, scale, nature and magnitude of its potential impacts, and the availability of cost-effective mitigation measures. According to NCRPB ESMS, the projects are screened for their expected environmental impacts and are assigned to one of the following categories: E1, E2 or E3.

Table 2-1: Environmental Category

Environmental Scenario	NCRPB's Categorization	MOEFs Categorization	ADB Categorization
Significant impacts or in eco-sensitive area	E1	A	A
Limited impacts	E2	B1 or B2 or No Category	B
No impacts	E3	No Category	C

- (i) Significant impacts or in eco-sensitive areas (Category E1): If the project has significant adverse environmental impacts that are irreversible, diverse, or unprecedented, then it is regarded to have environmental scenario. These impacts may affect an area larger than the sites or facilities subject to physical works. These impacts will be considered significant if these are in eco-sensitive areas.
- (ii) Limited environmental impacts (Category E2): If the project has impacts that are site-specific, few if any of them are irreversible, and in most cases mitigation measures can be designed.
- (iii) No environmental impacts (Category E3): If the project is likely to have minimal or no adverse environmental impacts, then it is regarded to have this environmental scenario.
14. The proposed subproject of construction of flyover at Mohan Nagar Junction in Ghaziabad is unlikely to have significant impacts. The project site is also not located or near any eco-sensitive area. The subproject is however likely to have typical impacts associated with the construction activity in urban areas and therefore classified as Category E2.
15. According to ESMS, E2 projects require carrying out Initial Environmental Examination (IEE) and preparation of IEE Report. This IEE report is prepared accordingly.

3. DESCRIPTION OF PROJECT

A. Project Need

16. Patel Chowk (Mohan Nagar Junction) on NH 24 is one of the critical locations that carry a high volume of traffic in Ghaziabad. The speed survey conducted on this stretch of the highway indicated a peak hour average speed of 19 KMPH. The study has mandated a flyover to be built at this junction (intersection of roads from NH24/Madan Mohan Malviya/Loni Road) by 2015. Location and proposed orientation of flyover is presented in **Figure 3-1** and **Figure 3-2**.
17. From the traffic analysis carried out, it can be seen that a flyover is mandated at this location in 2015 (**Table 3-1**). Based on this, an arrangement best suiting to the traffic pattern is proposed for improving the situation. Proposal is evolved giving due consideration to minimize the land acquisition. All the site constraints have been taken care while formulating the improvement scheme. The main objective is to improve the present condition and make the movement of traffic manageable to the possible extent.

Table 3-1: Projected Traffic at Mohan Nagar Junction

S. No	Year	Projected PCU
1	2010	6,867
2	2015	9,299
3	2020	11,893
4	2025	13,816
5	2030	14,632

Source: Traffic Prediction Analysis; PCU – Passenger Car Unit

B. Proposed Subproject

18. *Carriageway Width and Design Speed.* Taking into consideration the volume of traffic and pattern of movement, for decongesting the junction, it is proposed to provide a flyover along NH 24 which carries major share of traffic. This also segregates the through traffic from cross traffic. Based on the traffic requirement as per projections, a four lane configuration is proposed for the flyover and a two lane width is proposed for the service roads. Dual 2 lane carriageway separated by a central median is proposed for the flyover structure. Each 2 lane carriageway, intended for each direction of traffic, has a width of 7.5m with crash barriers of 0.5m width on extreme outer ends. The central median has a width of 1m. The existing alignment of NH 24 is followed for the flyover. Footpath cum drain of 2m is proposed. The ruling design speed of 100 KMPH is adopted for the flyover and at grade roads. Location and orientation of the flyover is shown in **Figure 3-1** and **Figure 3-2**.

**Capacity Development of
the NCRPB: Component B
(ADB TA-7055)**

**Location of Proposed Flyover at Mohan
Nagar Chowk**

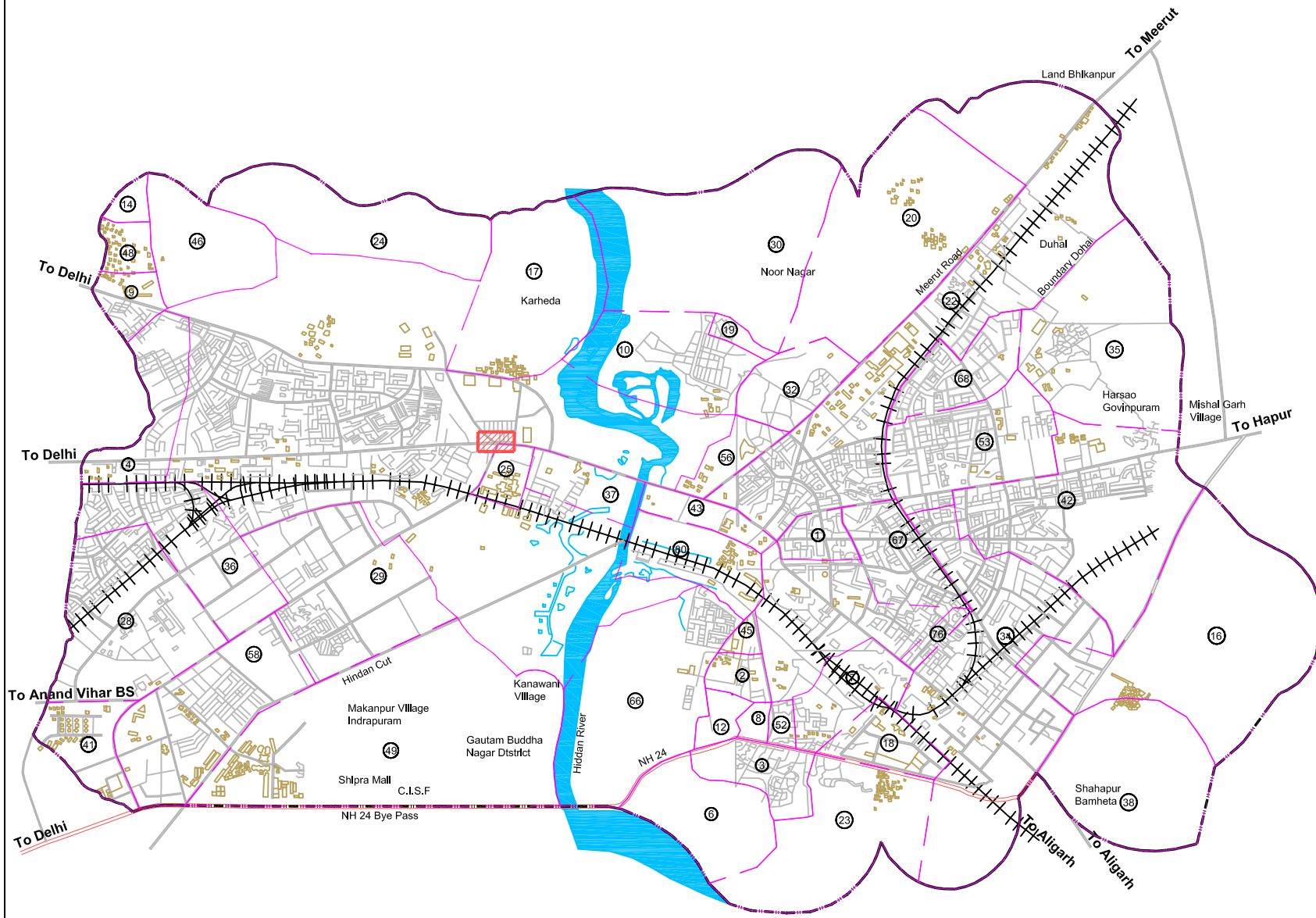

Legend

- Municipal Boundary
- Ward Boundary
- Ward Number
- National Highway
- Other Roads
- Buildings
- River, Stream
- Location of Flyover

Client
**Asian Development Bank
National Capital Region Planning Board**

Consultant
Wilbur Smith Associates

Drawn:SKG Checked: SKG
Approved: NSS

Scale: NTS

Figure 3-1

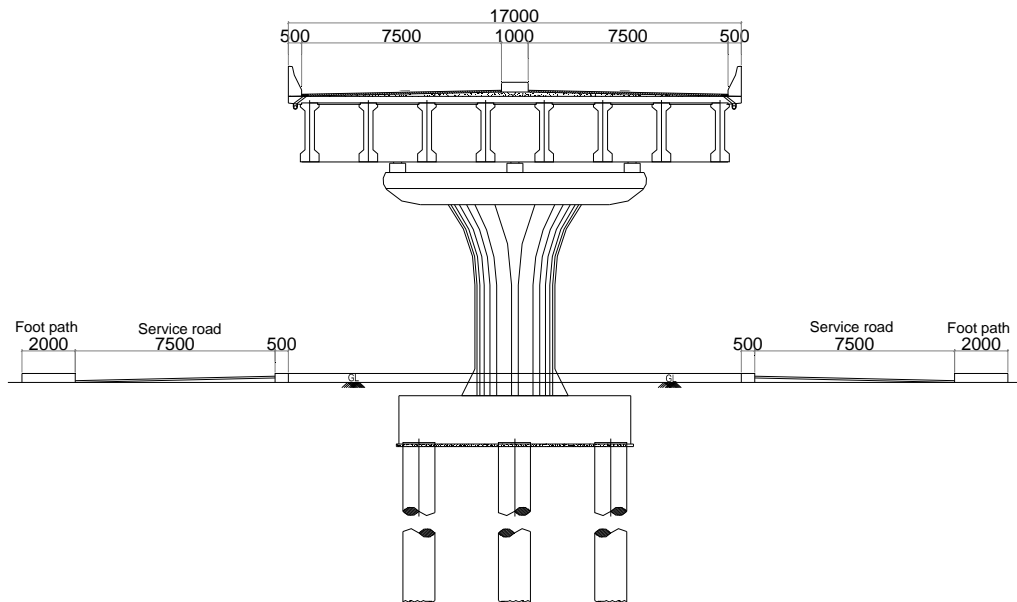

Figure 3-2: Orientation of Proposed Flyover at Mohan Nagar Chowk



19. The flyover is on structure except for a small length on either ends. Earthen ramps with earth retaining structures on sides are proposed beyond the abutments on either side. Minimum vertical clearance of 5.5m is proposed from the at grade road top to the bottom of deck at the junction.
20. The proposed flyover has a total length of 640 m with 16 numbers of spans of 40 m each, 5 numbers on Shahadara Border side and 9 numbers on Chandra Shekhar Chowk side apart from the two obligatory spans at the centre. The length of earthen ramp shall be 350 m and 200 m on Shahadara Border side and Chandra Shekhar Chowk side respectively. Thus the flyover and approaches including ramp portion shall have a total length of 1,190 m. The proposed flyover plan and profile is presented in **(Figure 3-4)**.
21. At grade road of 7.5m width is proposed on either side of the flyover as service road for local and turning traffic. Footpath cum drains is also proposed at the outer edges of these roads on both sides. The typical cross section of the proposed flyover is shown in the following **Figure 3-3**.

Figure 3-3: Typical cross section of flyover



22. *Right of Way.* The available ROW along NH 24 in the project site location varies from 36m to 39m. The Right of Way requirement for the proposed improvement is worked out to be maximum at the at grade section, which is 36 m. So the works will be taken up within the available ROW.
23. *Improvements to Existing Traffic Regulations.* The proposed flyover requires improvement and reorganization of the existing traffic arrangement at the junction. The traffic shall be channelized ensuring proper turning radius. To avoid conflicts between right turning traffic from Madan Mohan Malavya Marg and Loni Road, signal control is proposed at the junction. Traffic regulation arrangements like islands, signals etc now available are reorganized to facilitate smooth turning of vehicles.

TO SHAHADRA BORDER

TO CHANDRA SHEKHAR CHOWK

Capacity Development of the NCRPB: Component B (ADB TA-7055)

FLYOVER AT MOHAN NAGAR CHOWK PLAN & PROFILE

Ch. 0+000 to 1+000

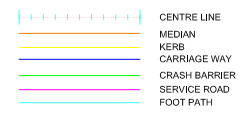
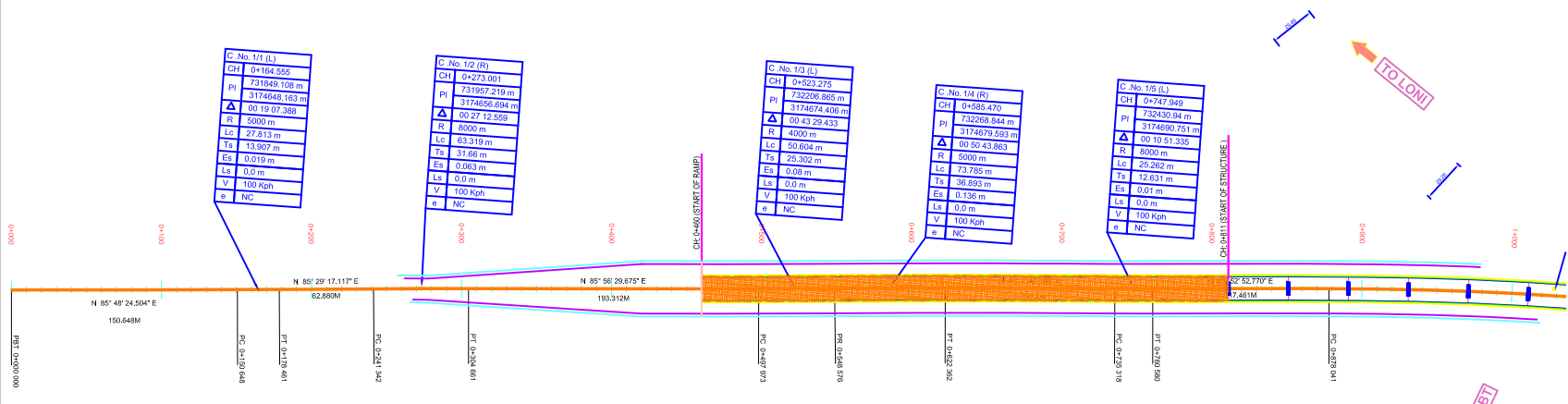
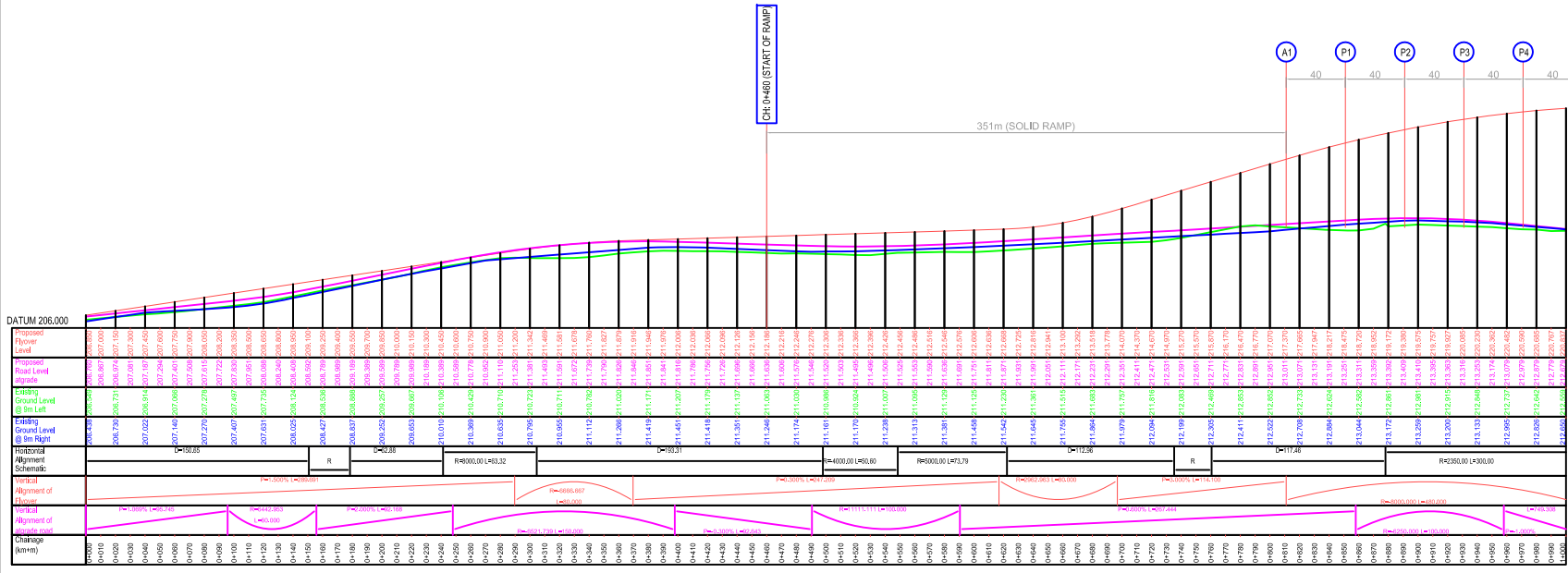

Client:
**Asian Development Bank
National Capital Region Planning Board**

Consultant:
Wilbur Smith Associates

Drawn: SSN
Date: Dec.2009
Scale: As shown

Checked: APK
Approved: AN

Sheet No.
1 of 2

Drawing No.
Figure 3-4

← TO SHAHADRA BORDER

TO CHANDRA SHEKHAR CHOWK →

Capacity Development of the NCRPB: Component B (ADB TA-7055)

FLYOVER AT MOHAN NAGAR CHOWK PLAN & PROFILE Ch. 1+000 to 2+170

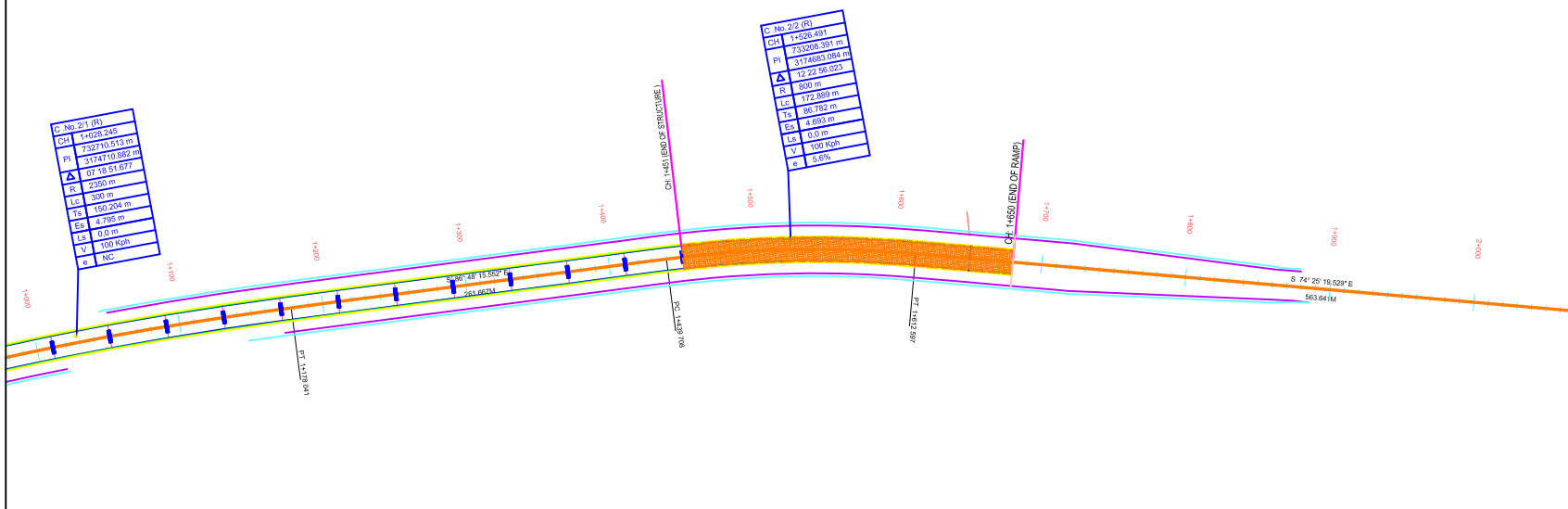
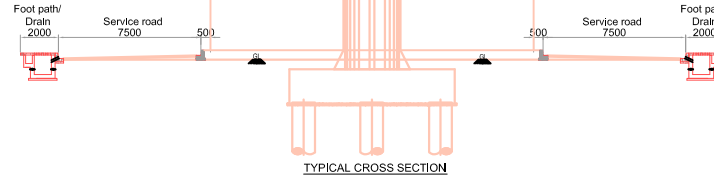
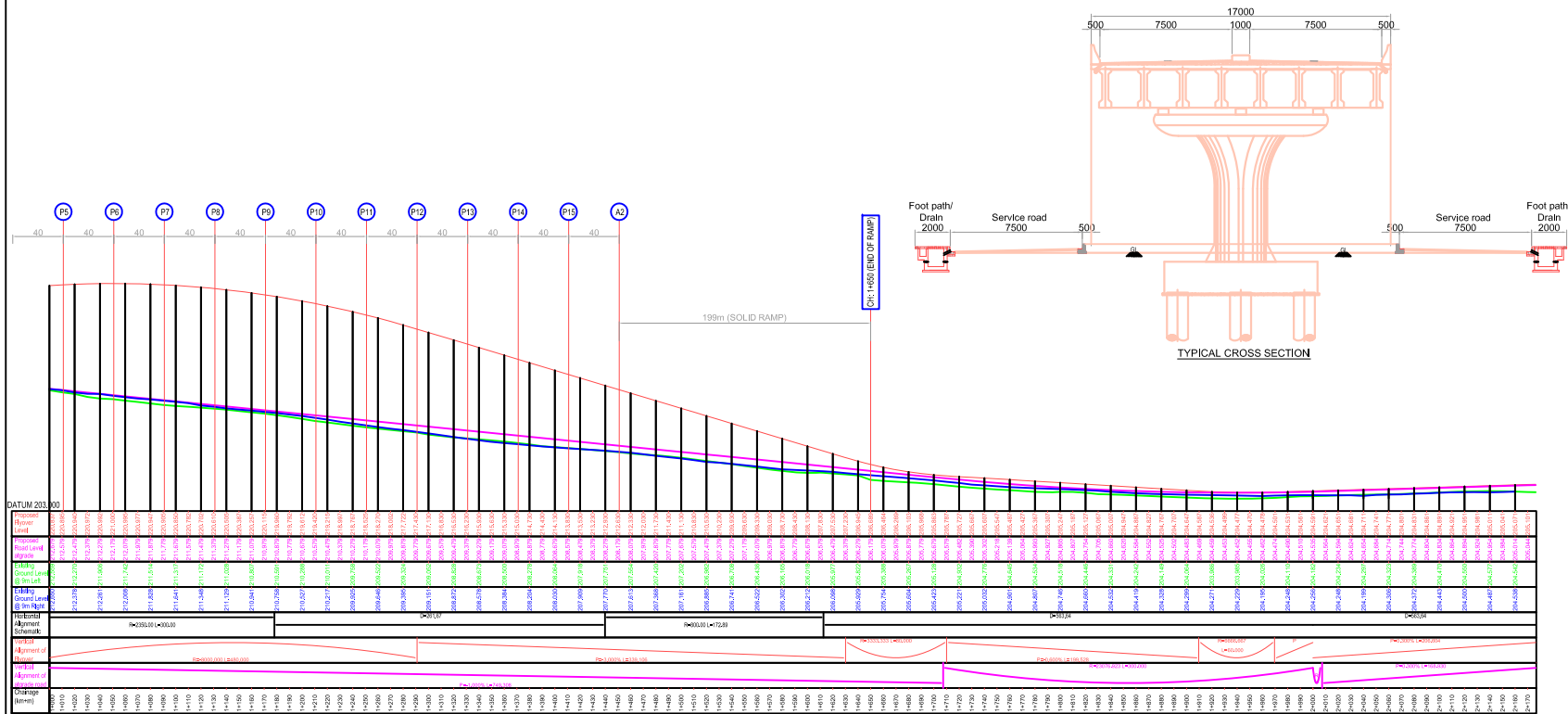

- CENTRE LINE
- MEDIAN
- KERB
- CARRIAGE WAY
- CRASH BARRIER
- SERVICE ROAD
- FOOT PATH

Client:
**Asian Development Bank
National Capital Region Planning Board**

Consultant:
Wilbur Smith Associates

Drawn: SSN
Date: Dec.2009

Checked: APK
Approved: AN

Sheet No.
2 OF 2

Scale: As shown

Drawing No.
Figure 3-4

24. *Salient Features of the Proposed Flyover.* Various structural arrangement options were studied for the proposed flyover based on: functional requirement; characteristics of subsoil; facilities to be provided at grade; ease in construction, and economy etc. Accordingly, the structural system was planned taking into account suitability of the same at the proposed location, constructability, level of impact on traffic movement during construction etc. A total of 16 spans of 40 m length are proposed for the elevated structure. The remaining portion is on earthen ramps on either side.
- (i) Superstructure: As longer spans are proposed, pre-stressed concrete superstructure is adopted. The four lane deck shall consists of 8 numbers of pre-cast post tensioned I-girders with in-situ RCC slab. The girders are spaced at 2.2 m. Cross diaphragms are proposed at support locations. The superstructure is supported by POT-PTFE bearings.
 - (ii) Substructure: The substructure proposed is RCC hammer headed piers with shaft flaring towards top portion and straight portion below is proposed. Single pier arrangement is proposed for the four line superstructure. Pier cap is cantilevered out to accommodate the girders. Height of pier is based on the clearance requirement. Where vehicles are to cross below, the minimum vertical clearance requisite of 5.5 m is ensured. At other support locations, the pier height varies in line with the road profile.
 - (iii) Foundation: Based on the geotechnical investigations on site, it is found that deep foundation is required at the location. Pile foundation is proposed to be taken to an average depth of 25 m from the ground level. The piles shall be of 1.2m diameter.
25. *At Grade Roads.* At grade roads with 7.5 m wide carriageway and 2.0 m wide footpath cum drains at the outer ends are proposed on either side of the flyover to cater for the turning traffic from cross roads. These roads are to be formed widening the existing pavement of NH 24; the existing road level is kept for the widened portion also.
26. The width of footpath has been derived from the volume of pedestrian traffic at the location. The drain shall have a width of 1.5m and is placed at the extreme end of the road.
27. *Utility Relocation Plan.* Proposal for shifting the utilities which fall within the project alignment have been prepared. The details of utilities falling along the project alignment are given in **Table 3-2Error! Reference source not found.** There are 33 lampposts present along the project alignment, which have to be removed, and lighting arrangement have been proposed in the flyover portion for both flyover and at grade roads. The cost for new lighting has been included in the cost estimates. There are 36 trees falling along the proposed flyover alignment, which have to be felled during the construction phase. As a compensatory measure, it is proposed to plant thrice the number of trees to be felled with site specific indigenous species and also to transplant the small trees wherever possible. For all the remaining utilities, shifting proposal is given.

Table 3-2: Details of existing utilities

S. No	Utilities	Number
1	Lamp post	33
2	Transformer	7
3	Telephone pole	1
4	Trees	36
5	Man hole	22
6	Electric pole	51

4. DESCRIPTION OF ENVIRONMENT

A. Physical Resources

1. Location

28. Ghaziabad City is located in the western part of Uttar Pradesh State sharing the borders with the National Capital Territory Delhi. It is the district headquarters of Ghaziabad District. Owing to its location close to Delhi, and with good connectivity, it is one of the important and fast developing city in the State of Uttar Pradesh and as well as in the National Capital Region. Geographically, Ghaziabad is situated at 28⁰ 40' N latitude and 77⁰ 25' E Longitude. Ghaziabad is situated at about 20 Km east of Delhi, and 432 km west of the State Capital, Lucknow.
29. It is well connected with important cities of the state and the country; three National Highways (NH 58, NH 91 and NH 24 - Delhi-Lucknow-Muradabad Road) pass through the City connecting it with Delhi, Meerut, Lucknow, Sikandrabad, Kolkata etc. Besides, it is well connected with its hinterland and surrounding towns by regional and local road network. The Main railway line and the two branches of northern railway (Meerut Branch & Moradabad Branch) pass through the City. It is an important railway junction in the Northern Railway. Base map of Ghaziabad is at **Figure 4-1**.





2. Topography, Soil and Geology

30. Originally established on the eastern side of River Hindon, present sprawling development of Ghaziabad can be observed on both sides of the River. Hindon River is an important tributary of Yamuna River of the Ganges River System. Flowing north-south, Hindon River passes through middle of the City and meets Yamuna about 35 km south of Ghaziabad. The topography of the City is almost plain and the general slope is from north to south.
31. Geologically, Ghaziabad forms a part of the Indo-Gangetic alluvium. Soil is characterized mainly by silty sand and loamy soils. Geotechnical investigations conducted at the proposed flyover site indicates that there is no hard rock till 25 m below ground level.
32. As per the seismic zoning map of India, Ghaziabad falls in sever intensity zone (Zone IV). However, there were no major earthquakes occurred in Ghaziabad till date.

**Capacity Development of
the NCRPB: Component B
(ADB TA-7055)**

**Ghaziabad
Base Map**

Legend

-  Municipal Boundary
-  Ward Boundary
-  Ward Number
-  National Highway
-  Other Roads
-  Buildings
-  River, Stream

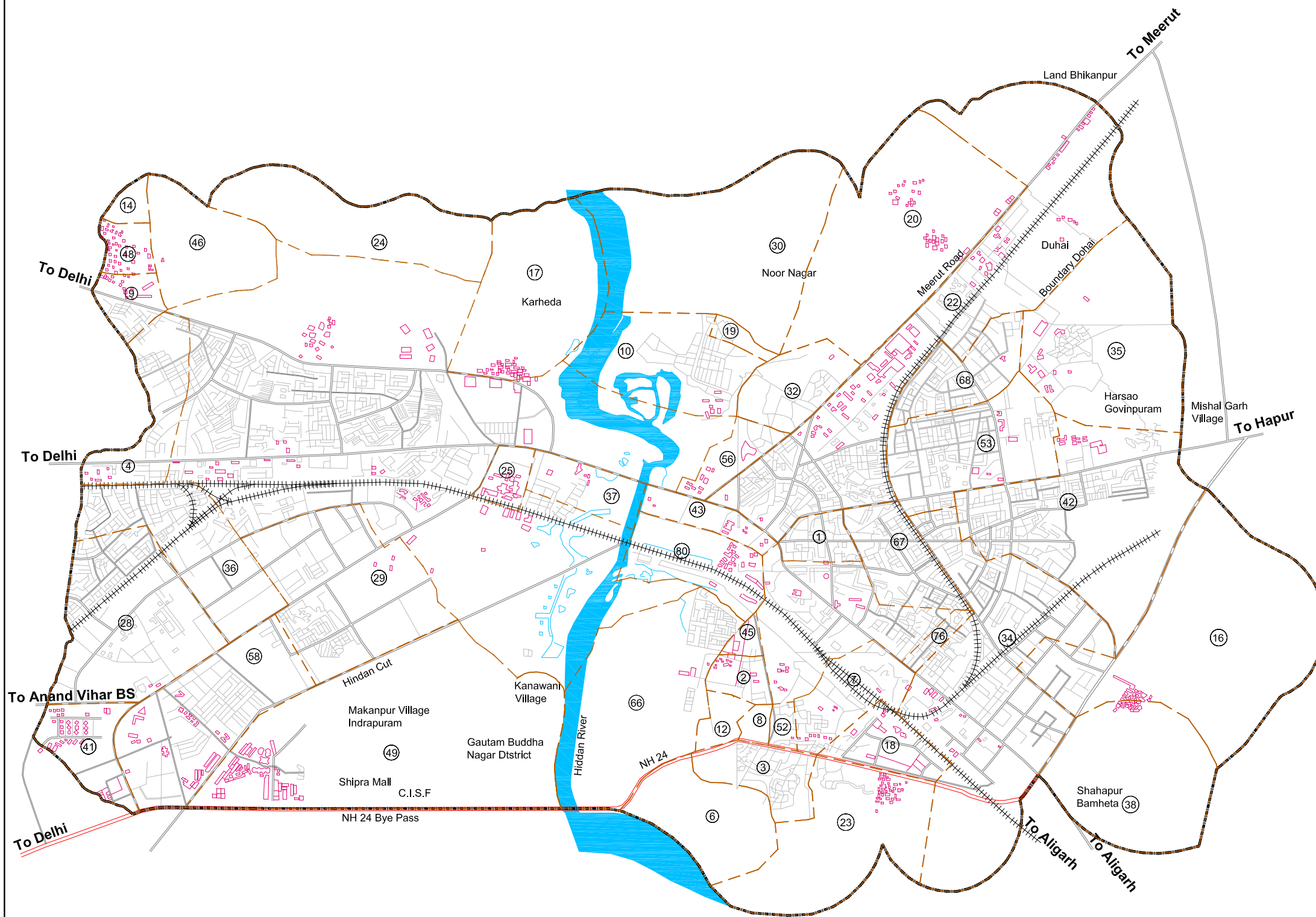

Client
**Asian Development Bank
National Capital Region Planning Board**

Consultant
Wilbur Smith Associates

Drawn: SK
Date: August, 2009
Scale: NTS

Checked: SKG
Approved: NSS

Figure 4-1



3. *Climate*

33. Typical humid subtropical climate of north India prevails in Ghaziabad, with high variation between summer and winter temperatures and precipitation. There are three distinct seasons – first of which is the monsoon season - hot and humid season from mid-June to September. Second season, winter, is the cool and dry season from October to March. The third phase, summer, is characterized by hot and dry weather which prevails from April to mid-June.
34. Rains in the region are concentrated in the monsoon season. The region receives rainfall mainly under the influence of southwest monsoon from July to September. Over 75 percent of the total rainfall is received during the monsoon months and the remaining rainfall is received during December to February. The annual average rainfall is 732 mm. Dust and thunderstorms occur in summer season while fog occurs in the winter.

Table 4-1: Rainfall Pattern in Ghaziabad (2004-2008)

Month	Rainfall (mm)					
	Normal	2004	2005	2006	2007	2008
January	20.5	7.8	0	0	0	NA
February	20.6	0	23.9	0	45	NA
March	17.4	0	19	NA	64	NA
April	5.8	30.4	0	0	0	NA
May	12.8	75	0	0	0	NA
June	43.8	20.6	80.5	34.2	64.1	16.4
July	216.5	36.8	185.7	250.5	84.1	124.4
August	234.5	520.6	57.9	20.4	99.8	58.1
September	129.2	50.4	284.2	114	4.7	8.7
October	34.1	12.6	0	16	0	0
November	4.3	0	0	0	NA	2
December	6.1	0	0	0	0	NA
Total	745.6	754.2	651.2	-	-	-

Figure 4-2: Long-term Annual Rainfall Pattern of Ghaziabad (in millimeter)

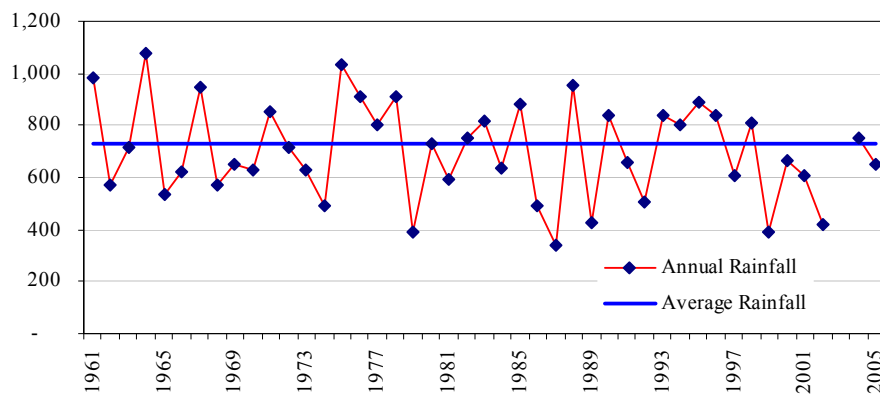

35. Owing to its sub-tropical continental monsoon climate with hot summers and cold winters, Ghaziabad experiences large variations in temperature across the year. May and June experiences high temperatures and the lowest is recorded in the months of December and January. **Figure 4-3** depicts the monthly averages of minimum, mean and maximum temperature. Winds predominantly blows from north, north-west and west direction, followed by from east and south-east direction.

Figure 4-3: Average Monthly Temperature (in Degrees Centigrade)

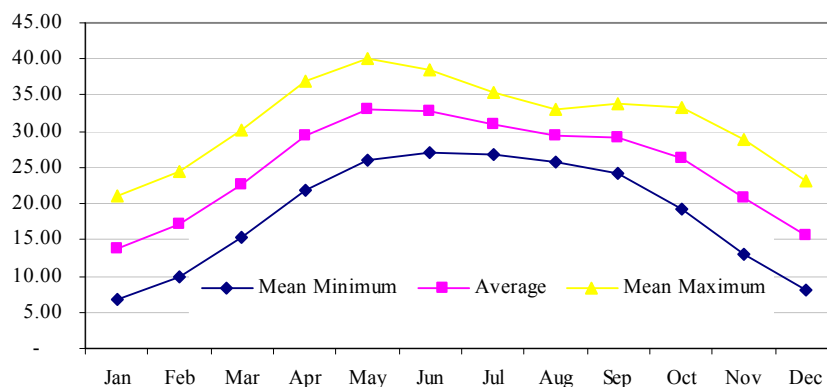

4. *Air Quality*

36. Ambient Air Quality in Ghaziabad is monitored by Uttar Pradesh Pollution Control Board (UPPCB). Due to dry weather coupled with dusty roads, particulate matter is high while levels of oxides of sulphur and nitrogen are well within the National Ambient Air Quality Standards (NAAQS). According to UPPCB, air pollution status in Ghaziabad has been termed as “low”.

Table 4-2: Air Pollution Status in Ghaziabad (2008)

Land use	Sulphur Dioxide (SO ₂)	Nitrogen Dioxide (NO _x)	SPM
Residential	L	L	C
Industrial	L	L	H

C – Critical; L – Low; H – High (see below Table for values); NA: Data not available

Table 4-3: Air Pollution Classification based on Annual Mean Concentration Range (µg/m³)

Air Pollution Status	Industrial Area		Residential Areas	
	SO ₂ & NO _x	SPM	SO ₂ & NO _x	SPM
Low (L)	0 – 40	0 - 180	0 – 30	0 – 70
Moderate (M)	40 – 80	180 - 360	30 – 60	70 - 140
High (H)	80 – 120	360 - 540	60 – 90	140 - 210
Critical (C)	>120	>540	>90	>210

Source: UPPCB

Table 4-4: NAAQ Standard – Annual Average Concentration in $\mu\text{g}/\text{m}^3$

Land use	RSPM	SPM	SO _x	NO _x
Residential	60	140	60	60
Industrial	120	360	80	80

Source: CPCB

5. *Surface Water*

37. Hindon River is an important tributary of Yamuna River of the Ganges River System. Hindon meets Yamuna about 35 km south of Ghaziabad. The confluence is located about 40 Km downstream of Okhla barrage. A short cut canal called the Hindon Cut joins River Yamuna at Okhla barrage from where the Agra canal takes off. The Hindon Cut, thus, serves to make the Hindon river water, including the supplemental discharge from the upper Ganga Canal, available for diversion to the Agra canal for irrigational use. The river stretch remains dry, except during rains. During winter and summer seasons, river flow is mainly limited to industrial effluents discharged from various industries located in Ghaziabad and as well as upstream areas.
38. Due to illegal entry of industrial and domestic wastewater, Hindon River water is polluted. As per the CPCB, the dissolved oxygen content in the river is low and BOD is present in notable quantities. Illegal disposal of untreated/partially treated effluent from textile dyeing and printing industries located in Shahid Nagar and Janakpuri in the trans-Hindon area are said to be one of the main reasons for pollution of Hindon River stretch in Ghaziabad.

6. *Groundwater*

39. Due to its location in Gangetic Plains, the underlain aquifers have good groundwater potential. However, the rapid development and increase in demand for water has put tremendous stress on groundwater reserves, both in terms of quantity and as well as quality. The groundwater decline is at much rapid phase and considering this alarming situation the Central Ground Water Authority (CGWA) has notified the area under GMC limits for regulation and control of groundwater extraction. No groundwater extraction is allowed without prior permission of Central Ground Water Board (CGWB).
40. General groundwater quality in Ghaziabad is good except in certain industrial and residential pockets where there is concentration of nitrates, fluorides and heavy metals beyond permissible limits. Indiscriminate disposal of untreated industrial and domestic wastewater is said to be the main reason for pollution of groundwater.

B. Ecological Resources

41. There are no forests or any other environmental sensitive locations in or near project site. Ghaziabad City is an urban area surrounded by land that was converted for agricultural use many years ago. There is no remaining natural habitat in the city, and the flora is limited to artificially planted trees and shrubs, and the fauna comprises domesticated animals plus other species able to live close to man. Tree cover along few main corridors is considerable; main tree species include Keekar (*Acacia karoo*); Neem (*Azadirachta indica*); Peepal (*Ficus religiosa*); Honge (*Pongamia Pinnata*); and eucalyptus.

C. Economic Development

1. Land Use

42. Owing to its location, adjacent to the National Capital, Delhi, over the years, Ghaziabad City has experienced a very rapid development and urbanization. Originally established on the eastern side of River Hindon, present sprawling development of Ghaziabad can be observed on both sides of the River. The City is almost merged with Delhi - City's development stretching towards Delhi on west side and vis-à-vis Delhi expanding to east towards Ghaziabad.
43. Ghaziabad Master Plan 2001 was formulated for an area of 100.4 sq. km, of which by 2001, about 84.8 sq. km was developed. As depicted in the following figure, the existing land use of Ghaziabad development area (84.8 sq km) shows that 60 percent of the land is under residential use followed by industrial areas. There are no agricultural areas within this development area. The gross density of the population is 130 persons per hectare. Anticipating a big growth in the near future, the Ghaziabad Master Plan 2021 has been formulated to an area of 155.54 sq. km.

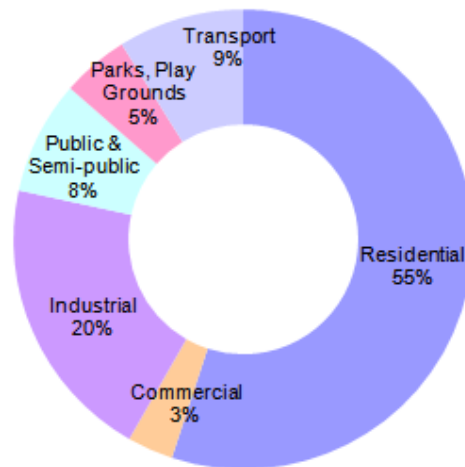
Figure 4-4: Existing Land Use

2. *Industry & Agriculture*

44. The City of Ghaziabad is known for medium and large scale industries. During 1970-80 decade a number of prestigious and large scale industries are established along Meerut Road, Bulandshahar Road, Link Road, Sahibabad and Loni Road in Ghaziabad City. In addition to UPSIDC developed industrial areas, there are a number of industries located in Mohan Nagar and Mohan Industrial Area. Ghaziabad houses a variety of industries including distilleries, chemical, engineering, steel, and textile and dyeing units etc.
45. Industrial sector is a major employment generator in Ghaziabad. Industrial development in Ghaziabad however declined in the decade of 1991-2001 and no new industries were established during that decade.
46. Within the city limits, there are no agricultural areas left. Almost all of the land is converted for residential or for other development.

3. *Infrastructure*

47. *Water Supply.* Two agencies are involved in provision of water supply service in Ghaziabad; while the state line agency Uttar Pradesh Jal Nigam (UPJN) is responsible for development of new infrastructure and all capital works, the Ghaziabad Nagar Nigam (GNN) is responsible for its day-to-day operation and maintenance. Water supply system in Ghaziabad is groundwater based. Water is extracted from 186 bore wells and a total of 160 MLD of water is supplied everyday at a rate of 145 LPCD (gross supply). In industrial areas, water is supplied by UPSIDC.
48. *Sewerage System.* UPJN carries out all new and capital works while the GNN operates and maintains the sewerage system in the City. Around 70-75 percent of the city population is covered with underground sewerage system. At present an estimated 128 MLD of sewage is generated in the City. There are 17 sewage pumping stations in the City to pump the

sewage to two sewage treatment plant for treatment and further disposal. The total treatment capacity available is 126 MLD however present usage is only about 71 percent. Industrial waste water treatment and disposal is managed by individual industries and UPSIDC.

49. *Solid Waste Management.* Municipal solid waste management is the responsibility of Ghaziabad Nagar Nigam. At present about 750 tons of solid waste is generated daily in Ghaziabad at a rate of 550 gm per capita per day. City is divided into five zones for better management of solid waste collection and disposal. There is no door-to-door collection system in the City. The solid waste is collected through bins located at various places in the neighborhood. Sanitary workers collect waste from bins and transport to disposal site at Sai Upvan on the banks of Hindon River. There is no proper disposal facility; the waste is disposed by crude open dumping method.

4. *Transportation*

50. Ghaziabad City is well connected with important cities of the state and the country; three National Highways (NH 58, NH 91 and NH 24 - Delhi-Lucknow-Muradabad Road) pass through the City connecting it with Delhi, Meerut, Lucknow, Sikandrabad, Kolkata etc. Besides, it is well connected with its hinterland and surrounding towns by regional and local road network. The main railway line and the two branches of northern railway (Meerut Branch & Moradabad Branch) pass through the City. It is an important railway junction in the Northern Railway.
51. It is 20 km east of Delhi and 46 km southwest of Meerut. Other roads lead northwest to Loni and Baghpat and east to Hapur and Garhmukteshwar. Buses run at frequent intervals to Delhi, Meerut, Aligarh, Bulandshahar, Moradabad, Lucknow and other cities. The City acts as the main entrance of Uttar Pradesh and is also called the “Gateway of Uttar Pradesh”.
52. Internal road network within the town is well developed. Most of the roads however are congested with traffic, pedestrians and activities such as parking of trucks/other vehicles and presence of informal business activities (squatters and vendors) within the ROW.
53. According to available 2003 data, over 70 percent of the vehicles in the town are two wheelers followed by cars. Internal travel in the city is mainly through public transport (buses and mini buses) and intermediate public transport system consisting of Auto Rickshaws.

D. Social and Cultural Resources

1. *Demography*

54. According to the national census the population of Ghaziabad was 968,521 in 2001, increased from 511,759 in 1991, recording an unprecedented growth rate of 89.3 percent over the decade. The population of overall GDA area in 2001 was 1,327,330, which was increased from 732,957 in 1991, with a growth rate of 81 percent.

Table 4-5: Population Growth of Ghaziabad City

Year	Population	Decadal Growth Rate (%)
1971	128,036	
1981	287,170	124.3%
1991	511,759	78.2%
2001	968,521	89.3%

Source: Census of India

55. Overall literacy is 80 percent, reported at 87 percent for males and 72 percent for females, which is considerably better than literacy in the state, which is 60.4 percent overall, and 75.7 percent for males and 44.0 percent for females. Sex ratio is however significantly below the natural 1:1 ratio, being 858 females per 1000 males, lower than both the state and national averages (879 and 929 respectively).
56. According to the Census 2001, workforce participation rate (WPR) in Ghaziabad was 28 percent. As shown in the following figure, nearly 95 percent of the total workforce was engaged in service sector (formal, informal, trade, commerce and industrial and other service sectors). Contribution of other sectors is very minimal – about 3.1 percent are engaged in household industries the remaining 2.3 percent of population are engaged in primary sector activities.

Figure 4-5: Occupational Structure

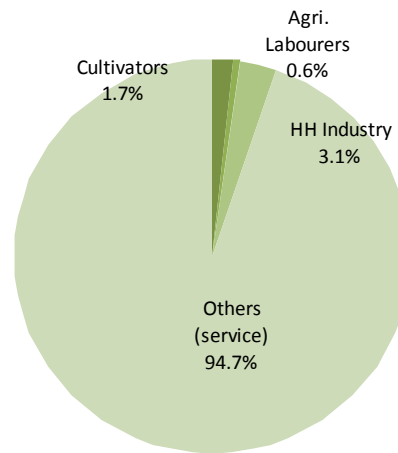

57. Majority of people in Ghaziabad are Hindus and the remainder are mainly Muslims, Sikhs, Jains, Christians and Bhudhists. Hindi is the main language of the area. Around 16% of the population belongs to scheduled castes (SC) category. Population belonging to Scheduled Tribe (ST) category in Ghaziabad are negligible and are part of the mainstream population.

2. *Health & Education Facilities*

58. Ghaziabad is a main centre for educational and health facilities in the region. There are a number of schools, colleges, professional education institutions, general and special health care facilities in the City, serving a large number of population from the City and the other near and far areas.

3. *History Culture and Tourism*

59. The City was founded in 1740 by the Emperor, Ghazi-ud-din, who called it Ghaziuddin Nagar after himself and built a spacious structure consisting of 120 rooms of masonry with pointed arches. Only the gate, a few portions of the boundary wall and a massive pillar about fourteen feet high remain now, the precincts now being inhabited. His mausoleum still stands in the city but is in a bad state. Ghaziabad played active role in the Indian freedom struggle, the revolt of 1857. An encounter took place between the freedom fighters and British force in Ghaziabad during that time. This was regarded as the first war of independence and it brought Ghaziabad much of its glory. On 14th November 1976, Ghaziabad became a separate district. Then on, Ghaziabad has developed in all fronts and it is now one of the biggest and fast developing centers in NCR.
60. There are no notified or protected monuments or sites of archeological and historical importance in the City. The tourism potential of is minimal.

E. Profile of Proposed Flyover Site

61. The proposed flyover will be constructed at Mohan Nagar Junction in Ghaziabad. This is a busy junction and carries heavy traffic throughout day and night. Traffic at this junction consists of traffic to and from Ghaziabad, Delhi, Loni and Shahadara and has considerable truck traffic owing to industries in the area.
62. Located in the northwestern part of the City, Mohan Nagar is predominantly an industrial area. Mohan Nagar Industrial Area houses a number of small, medium and large scale industries. Mainly industrial establishments abut the road stretch at this location; commercial and residential premises are very limited.
63. The total length of proposed flyover is 1,100 m. The existing right of way at the site ranges from 36 m to 39 m. A Police Station building and a Public Toilet are located within the ROW and therefore needs to be relocated for the proposed development.
64. The topography of the site is plain. There are no water bodies/streams traversing the road. During the geotechnical investigations conducted at the site, the groundwater had encountered at a depth of 21 m below the ground level. Four test bore holes of 25 m depth were drilled, and at all four locations the groundwater is encountered at the same depth. The geology and soil is characterized by silty sand and clay.
65. There are trees along the road on earthen shoulder and in traffic island, some of which needs to be removed for the subproject. All the trees are of domestic species and there are no endangered or protected species. The trees observed at the site include: Keekar (*Acacia karoo*); Neem (*Azadirachta indica*); Peepal (*Ficus religiosa*); Honge (*Pongamia Pinnata*); and Eucalyptus. Some of these young growing trees with girth size of not more than 300 mm. Some are old and degraded trees.



Photo 1: View of Flyover Site/Mohan Nagar Chowk



Photo 2: View of Proposed Site



Photo 3: Trees in the Traffic Island



Photo 4: Trees along the Service Road



Photo 5: Public Toilet in the RoW



Photo 6: View of the Road

5. ENVIRONMENTAL IMPACTS & MITIGATION MEASURES

A. Overview

66. As a general practice, an IEE should evaluate impacts due to the location, design, construction and operation of the project. Construction and operation are the two activities in which the project interacts physically with the environment, so they are the two activities during which the environmental impacts occur. In assessing the effects of these processes therefore, all potential impacts of the project should be identified, and mitigation is devised for any negative impacts. Following sections evaluate the impacts of the proposed Flyover Subproject in Ghaziabad.

B. Construction Impacts

67. This subproject will involve construction of the following elements at Mohan Nagar Junction in Ghaziabad:
- Flyover, 17 m wide and 5.5 m and 640 m length with 16 spans of 40 m each, supported on 17 centrally located RCC piers
 - Two earthen ramps (one 200 m and other 350 m) to form approaches to the flyover.
 - At grade service roads of 7.5 m wide on either side of flyover with 2 m wide footpath. These roads will be formed widening the existing pavement

Table 5-1: Construction Method & Materials of Flyover

Element	Construction Details	Construction Activities
Flyover Structure	Foundation: Pile foundation 17 pile foundations for 17 piers to support the flyover structure; RCC cast in-situ piles of dia 1.2 m and depth 25 m. Number of piles for each foundation varies from 6 to 8 and will be placed at a centre to centre distance of 3.6 m	Excavation and construction will be done simultaneously – a void is formed by boring or excavation and piles are produced by casting concrete in the void. Construction will be conducted in mechanized way. Heavy-duty machinery such as drilling machines, cranes, concrete mixers, vibrators etc will be used.
	Substructure: RCC Piers with cantilever pier cap to get the required span to accommodate girders	The reinforcing rods will extend out of the foundations to create the structure of each pier, and these will then be encased in shuttering, into which more concrete will be poured to form each pillar. Ready mixed concrete will be used. Construction equipment used will be cranes to lift shuttering and ready mix concrete trucks and concrete vibrators/compactors.

Element	Construction Details	Construction Activities
	Superstructure: Pre-cast I-girders with in-situ RCC slab	Pre-cast girders, casted at a manufacturing unit, will be brought to the site and placed over piers using heavy-duty cranes. Post-tensioning will be carried out using heavy-duty hydraulic jacks mounted on piers. The RCC slab will be casted in situ. Reinforcing bars will be fixed over a steel platform and the ready mixed concrete will be poured and compacted using vibrators to form the slab.
Ramps – approach to flyover	Earthen ramps with earth retaining structures; length of ramps will 200 m on one-side and 350 m on other side.	Earth retaining structure will be of interlocking concrete blocks placed on either side to form wall like structure of required height. Earth brought from quarries and excavated soil at the soil be used to fill the ramp. Soil will be compacted and over which a bituminous road will be formed. Construction equipment used will be: Cranes, earth moving equipment, rollers and compactors bitumen pavers.
At grade roads	7.5 m bituminous road with 2 m wide foot path over 1.5 m drain	The existing pavement will be widened to accommodate service roads. Sub grade and base course will be formed. Equipments used will be earth moving equipments, rollers and compactors and bitumen pavers.

68. Total quantity of earthwork excavation has been estimated as 18,694. Most of this will be utilized in construction of earthen ramps, which requires an estimated 17,845 sq. m. Construction materials like gravel, stone aggregate and sand will be sourced from quarries approved by the respective Mines & Geology Departments. Yamuna Nagar in Haryana about 200 km away is a known source for stone aggregates, Ghaghar, 180 km away and Haridwar, 160 km away are sources for sand and Noida, 30 km away for soil. Bitumen will be procured from refineries.

1. *Impacts on Physical Resources*

69. Although all work will be conducted at a single, relatively small site, construction will involve a great deal of excavation and earth moving over a period of approximately nine months, so physical impacts could be quite considerable.
70. As detailed above, the work involves significant quantities of earthwork excavation as well as filling works. In earthwork most of the impacts are related to mining/borrow pits and disposal of surplus soil. However, this is avoided by proposing to use the excavated soil for formation of earthen ramps. Thus, the net quantity of soil that needs to be disposed

is about 850 m³, which can be disposed off without any problems. This can also be utilized for filling up of low-lying areas.

71. Overall, the quantity of earthwork conducted at the site will be over 36,000 m³ (including both excavation and filling). Moving such a large quantity of soil could cause physical impacts, including the creation of dust during dry weather and silt-laden runoff during rainfall, both of which would affect people who live and work near the site and reduce the quality of adjacent land. Earthwork will not mostly be conducted in rainy season, so this will avoid any problems from runoff. In Ghaziabad, dry weather prevails in most part of the year, and therefore generation of dust may be significant. It will therefore be necessary to prevent dust, which could be generated in quite large quantities. The Contractor should therefore:

- Cover or damp down by water spray on the excavated mounds of soil to control dust generation
- Damp down soil while moving from excavation area to earthen ramp portion
- Bring the material (aggregate) as and when required;
- Use tarpaulins to cover loose material/soil that is transported to and from the site by truck
- Damp down soil sufficiently while using for leveling the ground
- Control dust generation while unloading the material (particularly aggregate) at the site by sprinkling water and unloading in a barricaded area
- Sprinkle water in truck after downloading material; or cover it with tarpaulin to avoid dust razing from the truck while it is moving

72. The excavation to create the foundations for the piers and abutments could affect local drainage patterns as rainfall will collect in the voids instead of running onto surrounding land or into storm water drains, but this impact will also be avoided by conducting the work in the dry season. The work should be conducted at the same time as construction of the ramps so that excavated material is utilized immediately, avoiding the need to stockpile large quantities of excavated soil, which could create dust. Any soil that is stockpiled should be damped down during dry weather as noted above.

73. As the deep excavations will be made for foundations, it is possible that the groundwater may be collected in voids, which need to be pumped out. This silt-laden runoff may accumulate on the ground or choke the local drains, creating nuisance and unhealthy environment. However, considering that groundwater table depth of 21 m below ground level, and the proposed excavation depth of 25 m for pile foundations, the water gushes out of pit will be very minimal. Nevertheless the contractor should implement the following measures:

- Do not divert/dispose silt laden water into drains directly
- Provide temporary ponds in the site for temporary storage; dispose clarified water into nearest drains
- Ensure that disposal into drains do not lead to water accumulation in the nearby areas

74. Creation of ramps will gradually alter the topography and appearance of the site. Drainage of the site needs to be modified with suitable drains to suit the changed topography to avoid flooding and accumulation of water. These are included in the project design. One possible impact on drainage is that existing drains have to be relocated to the edge of the expanded roadway and therefore needs to be stopped during the construction work. During this transitional phase, the following measures shall be implemented to avoid water accumulation due to disruption of drains:

- Divert existing drains in the working section (ROW) temporarily; construct a temporary drain if required
- Complete construction of new drain as soon as possible and restore the flow

2. *Ecological Resources*

75. There are no protected areas in or around the site and no known areas of ecological interest. However, construction of flyover requires cutting of 36 trees of domesticated species including Keekar (*Acacia karoo*); Neem (*Azadirachta indica*); Peepal (*Ficus religiosa*); Honge (*Pongamia Pinnata*); and Eucalyptus. Some of these young growing trees with girth size of not more than 300 mm. Some are old and degraded trees.
76. Cutting of trees could not be avoided as the trees are located within the ROW. Necessary approvals from competent authority (Forest Department/Ghaziabad Nagar Nigam) shall be obtained and the guidelines for compensatory measures, if any of the competent authority, must be adhered to. In any case, as a compensatory measure, three trees will be planted and maintained for each tree felled.

3. *Economic Development*

77. The work will be conducted within the available ROW and therefore no land acquisition is envisaged. However, there are some encroachments in the form of squatters which needs to be cleared off for the project. All 19 squatters are commercial squatters squatting upon the ROW and they run their small business like tea stalls, vehicle repairing shop etc and earn their livelihood. NCRPB Environmental and Social Management System (ESMS) and Policy provides that the owners and tenants of these businesses do not suffer economically as a result of the project, and a Resettlement Plan have been prepared to assess the nature and extent of the losses and the compensation that is needed. This indicates that owners and tenants of businesses that will lose property, other assets and/or income as a result of the project will be provided with:

- Compensation equivalent to the amount of business income lost as a result of the construction process;
- Compensation at replacement cost for lost income-generating assets (shop premises, etc);
- Additional financial assistance to enable them to re-establish their business at an

alternative location.

78. Some shops and other premises along the road may lose business income because the presence of the construction site will deter customers, and at some locations access will be impeded by road closures, and by the presence of heavy vehicles and machinery, etc. These impacts will be avoided by confining the construction area to the actual area in the middle of the road and allowing the traffic to move on the service roads on either side. The construction area will be confined and barricaded. Moreover, there are almost no commercial establishments such as shops, markets in this stretch of road which is mostly occupied by industries.
79. Transportation is the principal activity that will be impeded by this work. Although the traffic can move on the service roads, there will be disturbance and overcrowding of vehicles. Following measures are therefore required to be implemented:
- Maintain the service roads in good condition to allow smooth traffic movement; provide necessary personnel to guide and control the traffic
 - Provide alternative traffic arrangement/detours so that traffic can be distributed and move on different roads; and, ensure that public is informed about such traffic diversions
 - Provide information to the public through media – daily news papers and local cable television (TV) services about the need and schedule of work, and alternative routes
 - At the work site, public information/caution boards shall be provided - information shall inter-alia include: project name, cost and schedule; executing agency and contractor details; nature and schedule of work; traffic diversion details, if any; entry restriction information; competent official's name and contact information for public complaints.

4. *Social and Cultural Resources*

80. There are no historical or cultural heritage sites in Ghaziabad in general or at the project site in particular. Therefore there are no likely impacts.
81. There are no modern-day social and cultural resources (such as schools and hospitals) near the site, and no areas that are used for religious or other purposes, so there is no risk of other impacts on such community assets.
82. In the ROW there is a Police Station, two Bus Bays and a public toilet, which needs to be removed and relocated from the ROW as part of the project. These will suitably be accommodated within the vicinity.
83. Although residential and commercial establishments along the road and in the vicinity are minimal, action should be taken to minimize disturbance as far as possible. This will require:

- Consultation with the local community to inform them of the nature, duration and likely effects of the construction work, and the mitigation measures in place
 - Proper planning of work programme so that any particularly noisy or otherwise invasive activities can be scheduled to avoid sensitive times;
 - Avoiding noise-generating activities at night;
 - Implementing the measures to reduce dust;
 - Utilising modern vehicles and machinery with the requisite adaptations to limit noise and exhaust emissions, and ensuring that these are maintained to manufacturers' specifications at all times.
84. There is invariably a safety risk when substantial construction such as this is conducted in an urban area, and precautions will thus be needed to ensure the safety of both workers and citizens. The Contractor will be required to produce and implement a Site Health and Safety Plan. This should include such measures as:
- Following standard and safe construction practices;
 - Excluding the public from the site – enclosing/barricading the construction area; providing warning boards and sign boards and posting of security guards throughout the day and night
 - Ensuring that all workers are provided with and use appropriate Personal Protective Equipment (helmet, hand gloves, boots, masks, safety hoists when working at height, etc);
 - Barricade the entire area that may come under influence in case of accidents – this may particularly critical during fixing of pre-cast girders using heavy duty cranes; this may be conducted during lean traffic periods and if required the traffic may also be stopped for that short duration
 - Follow standard practices of safety checks as prescribed before use of equipments such as cranes, hoists, etc.
 - Employ an Environmental, Health and Safety (EHS) Expert on site;
 - Provide on -site Health and Safety Training for all site personnel;
 - Report accidents to the authorities promptly, and maintain records
85. There could be some short-term socio-economic benefits from the construction work if local people gain employment in the workforce. To ensure that these benefits are directed to local people, the Contractor should be required to employ as much of his labour force as possible from the local communities in the vicinity of construction sites. Drawing of majority of workforce from local communities will avoid problems that can occur if workers are imported, including social conflicts and issues of health and sanitation due to labour camps. If temporary labour camps are to be provided; Contractor should ensure that they are maintained well with proper water supply and sanitation facilities.

C. Operation Stage Impacts

86. The roads and bridges generally operate without the need for major maintenance or repair,

therefore there are no major impacts envisaged. During its design life, the flyover should require no major repair or refurbishment, beyond routine maintenance like small scale ad hoc repairs of surface damage caused by traffic use or accidents; repairs and replacement of damaged safety barriers and signs, etc.

87. The stability and integrity of the bridge should also be monitored periodically to detect any problems and allow remedial action if required.

1. *Physical Resources*

88. Once the flyover is completed and operating it will improve the physical environment by removing the severe traffic congestion that is a feature of this location at present, with the resulting concentration of vehicle noise and pollution. This will be replaced by a modern elevated roadway, which allows the maintenance of a smooth flow of traffic at different grades/levels.
89. The Flyover will however elevate the traffic significantly above ground level, making the traffic and the structure significantly more visible than at present. However considering the land use around the road with industrial areas and no aesthetically beautiful areas, visual impacts of flyover will be negligible. Planting of large growing native trees, which would mask the structure to give a more pleasing appearance, may be considered where land is available within the ROW. This may however be considered with due consideration to safety of traffic, pedestrians.
90. Although the flyover is located in an area of high seismic risk, it will be designed according to standard Indian Engineering Design Codes, which include measures to allow the structure to withstand tremors of the expected magnitude and above. There should therefore be little risk of the structure failing, even if the area is subject to seismic events of greater magnitude than those that have occurred over recent years.

2. *Ecological Resources*

91. As there are no significant ecological resources in or around the town, the operation of the flyover and the routine maintenance and repair of the road and surroundings will have no ecological impacts. There would be some small ecological gain from the planting of trees to mask the visual impact of the structure.

3. *Economic Development*

92. The flyover will improve the infrastructure of the city by providing a more efficient and effective transportation route, and this should have positive impacts on the overall economy by reducing time spent idle in stationary traffic by delivery vehicles, employees and customers.

4. *Social and Cultural Resources*

93. There are unlikely to have any negative impacts on these resources. The citizens of the city will benefit from a more effective transportation route as they will spend less time in stationary traffic exposed to noise, pollution and the associated physical and psychological stresses. Social and cultural resources may also benefit in a small way as it will be easier for people to reach their destinations. People may also benefit from an improvement in the economy of the city, although it would require much larger improvements in transportation and other infrastructure for this to be recordable.

D. Location and Design Impacts

94. In many environmental assessments there are certain effects that, although they will occur during either the construction or operation stage, should be considered as impacts primarily of the location or design of the project, as they would not occur if an alternative location or design was chosen.

95. However in case of this subproject it is not considered that there are any impacts that are a result of the design or location. This is because:

- The project will be built at a single relatively small location and involves straightforward construction and low-maintenance operation, in an environment that is not especially sensitive, so it is unlikely that there will be major impacts;
- Most of the predicted impacts are associated with the construction process, and are produced because that process involves quite extensive groundwork. However the routine nature of the impacts means that most can be easily mitigated.

6. INSTITUTIONAL ARRANGEMENTS

A. Institutions Involved

96. Following agencies will be involved in implementing this Flyover construction subproject at Mohan Nagar Junction in Ghaziabad:
- (i) NCRPB: National Capital Region Planning Board is the funding agency for the project.
 - (ii) Implementing Agency (IA): Implementing Agency of the Project will be Ghaziabad Development Authority. IA will be responsible for the project implementation. Operation & maintenance will also be the responsibility of the IA.
 - (iii) Design and Supervision Consultants: Implementing Agency will be assisted by Design and Supervision Consultants (DSC) in tendering, and reviewing and revising designs during the construction, if required, and supervising the construction to ensure quality.
 - (iv) Construction Contractors: IA will appoint Construction Contractors (CC) to build the infrastructure elements.
97. Implementing the project according to and in compliance with the policies the funding agency, NCRPB, will be the responsibility of the Implementing Agency (IA). The Environmental and Social Management Cell (ESMC) of NCRPB will deal with environmental and social safeguard issues. ESMC would guide and monitor IA in complying with its ESMS and Policy.
98. *ESMC*. The ESMC will be housed inside the appraisal function of NCRPB and will have two distinct sub-functions, i.e. managing environmental safeguards and social safeguards. ESMC will be provided with one full-time staff - safeguards officer, who will look after the day-to-day activities related to the safeguard compliance. Safeguard Officer will be responsible for both environmental and social safeguard functions. Based on the necessity, the Safeguards Officer will source expertise from outside/external consultants on a case-to-case basis.
99. ESMC will review and approve IEE, oversee disclosure and consultations, and will monitor the implementation of environmental monitoring plan and environmental management plan where required. The Construction Contractor (CC) will implement mitigation measures in construction. IA or DSC will monitor the implementation of mitigation measures by the CC. ESMC will oversee the implementation of EMP. Implementation of mitigation and monitoring measures during the operation and maintenance (O&M) stage will be the responsibility of the implementing agency.

7. ENVIRONMENTAL MANAGEMENT PLAN

A. Environmental Management Plan

100. The proposed subproject and its components, the baseline environmental profile of the subproject area, the anticipated environmental impacts and appropriate mitigation measures to avoid/ reduce/ mitigate/compensate for the identified impacts have been discussed in detailed in earlier sections.
101. This Environmental Management Plan is developed for implementation listing the impacts, appropriate mitigation measures, delegating the responsibility of implementation to concerned agencies. This is shown in the following **Table 7-1**.

B. Environmental Monitoring Plan

102. A program of monitoring will be conducted to ensure that all the parties take the specified action to provide the required mitigation, to assess whether the action has adequately protected the environment, and to determine whether any additional measures may be necessary. Regular monitoring of implementation of mitigations measures by Construction Contractor will be conducted by the Implementing Agency. Periodic monitoring and overseeing of implementation of mitigation measures will be conducted by the ESMC of NCRPB. Monitoring during operation stage will be conducted by the Operating Agency.
103. Most of the mitigation measures are fairly standard methods of minimizing disturbance from building in urban areas (public inconvenience and traffic disruptions). Monitoring of such measures normally involves making observations in the course of site visits, although some require more formal checking of records and other aspects.
106. **Table 7-2** shows the proposed Environmental Monitoring Plan (EMP) for this Project, which specifies the various monitoring activities to be conducted during different phases of the project. The EMP describes: (i) mitigation measures, (ii) location, (iii) measurement method, (iv) frequency of monitoring and (v) responsibility (for both mitigation and monitoring).

Table 7-1: Environmental Management Plan

Potential Negative Impacts	Sig	Dur	Mitigation measures	Responsibility	Location	Cost
Preconstruction						
Involuntary resettlement <i>Description:</i> Displacement of 19 squatters encroached on the ROW	L	P	<ul style="list-style-type: none"> • Implement compensatory measures as recommended by the Resettlement Plan prepared in accordance with NCRPB ESMS • Suggested measures must be implemented before the signing of contract for civil works including: <ul style="list-style-type: none"> ○ Compensation equivalent to the amount of business income lost as a result of the construction process; ○ Compensation at replacement cost for lost income-generating assets (shop premises, etc); ○ Additional financial assistance to enable them to re-establish their business at an alternative location. 	GDA	Flyover site	Part of RP Cost
Construction						
Tree Cutting <i>Description:</i> The proposed work requires cutting of 36 trees of domesticated and local species			<ul style="list-style-type: none"> • Obtain necessary approvals from Forest Department/Ghaziabad Nagar Nigam for tree cutting • Plant and maintain three trees for each tree felled as a compensatory measure 	CC	Flyover site	Part of project cost
Excavation will produce large quantity of waste soil, which needs proper disposal. <i>Description.</i> Excavation for bridge construction will produce an estimated 18,694 m3 of waste soil. This however will be utilized in construction earthen ramps, which require an estimated 17,845 m3 of	L	P	<ul style="list-style-type: none"> • Utilize surplus soil for beneficial purposes such as in construction activities elsewhere and filling up low-lying areas 	CC	Flyover site	Part of standard contract

Potential Negative Impacts	Sig	Dur	Mitigation measures	Responsibility	Location	Cost
soil. So the surplus soil that requires proper disposal will be minimal.						
<p>Dust nuisance due to construction</p> <p><i>Description.</i> Earthwork excavation, refilling, handling and transportation of construction materials (like sand and aggregate), and handling, transportation and construction of earthen ramps will produce large volumes of dust if it is not done properly. Total quantity of earthwork involved in laying/replacing of distribution and rising main is about 260 thousand cubic meter, including 9,500 m3 of surplus soil for disposal.</p>	M	T	<ul style="list-style-type: none"> • Cover or damp down by water spray on the excavated mounds of soil to control dust generation • Damp down soil while moving from excavation area to earthen ramp portion • Damp down the surface of the developing ramps and any soil stockpiled on site by spraying with water when necessary during dry weather; • Use tarpaulins to cover soil/materials when transported by truck • Bring the material (aggregate) as and when required; • Use tarpaulins to cover loose material/soil that is transported to and from the site by truck • Damp down soil sufficiently while using for leveling the ground • Control dust generation while unloading the material (particularly aggregate) at the site by sprinkling water and unloading an a barricaded area • Sprinkle water in truck after downloading material; or cover it with tarpaulin to avoid dust raging from the truck while it is moving 	CC	Flyover site & material and waste construction routes	Part of standard contract
<p>Impacts on drainage</p> <p><i>Description.</i> During deep excavation for pile foundation, there is a possibility of water collecting in the void, needing disposal. Indiscriminate disposal of this silt – laden water may choke drains, lead to water accumulation etc. Also, existing drains in the ROW will be disturbed.</p>			<ul style="list-style-type: none"> • Do not divert/dispose silt laden water into drains directly • Provide temporary ponds in the site for temporary storage; dispose of clarified water into nearest drains • Ensure that disposal into drains do not lead to water accumulation in the nearby areas • Divert existing drains in the working section (ROW) temporarily; construct a temporary drain if required • Complete construction of new drain as soon as possible and restore the flow 	CC	Flyover site	Part of standard contract

Potential Negative Impacts	Sig	Dur	Mitigation measures	Responsibility	Location	Cost
<p>Generation of noise and vibrations from excavation</p> <p><i>Description.</i> High noise and vibration generating activities like rock blasting are not involved in the project. Construction activities in general like operation of heavy equipment, excavation for casting piles, braking up of road surface, may creates noise & vibration</p>	L	T	<ul style="list-style-type: none"> • Consultation with the local community to inform them of the nature, duration and likely effects of the construction work, and the mitigation measures in place • Do not conduct noise generating activities in the night • Employ manual methods, where required • Proper planning of work programme so that any particularly noisy activities can be scheduled to avoid sensitive times; • Utilize modern vehicles and machinery with the requisite adaptations to limit noise and exhaust emissions, and ensuring that these are maintained to manufacturers' specifications at all times. 	CC	Flyover Site	Part of standard contract
<p>Impacts due to improper mining for construction materials</p> <p><i>Description.</i> Large quantities of construction material like sand, gravel and aggregate will be required for construction work. Yamuna Nagar in Haryana about 200 km away is a known source for stone aggregates, Ghaghar, 180 km away and Haridwar, 160 km away are sources for sand and Noida, 30 km away for gravel.</p>	L	P	<ul style="list-style-type: none"> • Ensure that construction materials (sand, aggregate and gravel) are obtained from quarries licensed by Geology and Mining Departments of respective state governments (Haryana/ Uttar Pradesh /Uttarakhand) 	CC	NA	Part of standard contract

Potential Negative Impacts	Sig	Dur	Mitigation measures	Responsibility	Location	Cost
<p>Shops and other business may loose income if costumer's access is impeded</p> <p><i>Description.</i> There are no major commercial areas along the roads except few road side vendors. The disturbance however will be minimal as the road will not be closed completely and the traffic is allowed on service roads.</p>	L	T	<ul style="list-style-type: none"> • Inform the public in general and business establishments in particular about the work in advance • Maintain service roads and pedestrian walks in good condition • Control dust generation 	CC	Flyover site	Part of standard contract
<p>Excavation could damage existing infrastructure/utilities</p> <p><i>Description.</i> There are various utilities (electric poles, transformers and manholes) within the ROW, which needs to be relocated. No major impact envisaged as these utilities will be relocated suitably before the start of work. However, it needs to be confirmed during construction about the underground utilities.</p>	L	P	<ul style="list-style-type: none"> • Confirm location of underground infrastructure/utilities before start of work • Provide prior public information about the likely disruption of services • Ensure that alternate arrangements are provided during the relocation 	CC and respective agency (BSNL, UJS, GNN)	Flyover site	Part of standard contract

Potential Negative Impacts	Sig	Dur	Mitigation measures	Responsibility	Location	Cost
<p>Hindrance to traffic due to construction work</p> <p><i>Description.</i> As this is a major transport corridor carrying considerable traffic, the construction work will create large scale disturbance</p>	M	T	<ul style="list-style-type: none"> • Maintain the service roads in good condition to allow smooth traffic movement; provide necessary personnel to guide and control the traffic • Provide alternative traffic arrangement/detours so that traffic can be distributed and move on different roads and ensure that public is informed about such traffic diversions • Barricade the site properly; avoid accidental entry of traffic (pedestrian / vehicular) into site. • Provide information to the public through media – daily news papers and local cable television (TV) services, about the need and schedule of work, and alternative routes • At the work site, public information/caution boards shall be provided - information shall inter-alia include: project name, cost and schedule; executing agency and contractor details; nature and schedule of work; traffic diversion details, if any; entry restriction information; competent official’s name and contact information for public complaints. 	CC	Flyover site	Part of standard contract
<p>Increase in traffic due to trucks carrying construction material and heavy equipment</p>	L	T	<ul style="list-style-type: none"> • Plan routes to avoid narrow streets, congested roads, and places of religious importance • Plan work to avoid peak traffic hours 	CC	NA	Part of standard contract
<p>Workers and public at risk from accidents on site</p> <p><i>Description.</i> Deep excavations, operating heavy-duty construction equipment</p>	M	T	<ul style="list-style-type: none"> • Follow standard and safe construction practices • Exclude the public from the site – enclose/barricade the construction area, provide warning boards/ sign boards and post security guards throughout the day and night • Ensure that all workers are provided with and use appropriate Personal Protective Equipment (helmet, hand gloves, boots, masks, safety hoists when working 	CC	Flyover Site	Part of standard contract

Potential Negative Impacts	Sig	Dur	Mitigation measures	Responsibility	Location	Cost
			at height, etc); <ul style="list-style-type: none"> • Barricade the entire area that may come under influence in case of accidents – this may particularly be critical during fixing of pre-cast girders using heavy duty cranes; this may be conducted during lean traffic periods and if required traffic may also be stopped • Follow standard practices of safety checks as prescribed before use of equipments such as cranes, hoists, etc. • Employ an Environmental, Health and Safety (EHS) Expert on site; • Provide on -site Health and Safety Training for all site personnel; • Report accidents to the authorities promptly, and maintain records 			
Economic benefits for people employed in workforce	L	T	<ul style="list-style-type: none"> • Ensure that most of the unskilled workforce is from local communities 	CC	All sites	NA

Table 7-2: Environmental Monitoring Plan

Mitigation measures	Responsible for Mitigation	Monitoring Method & Parameters	Monitoring Frequency	Responsible for monitoring	Cost
Pre-Construction					
<ul style="list-style-type: none"> Implement measures as recommended by RP 	GDA	Records review; interview with APs	As needed	ESMC	Part of project management cost
<ul style="list-style-type: none"> Obtain necessary approvals for tree cutting Plant and maintain three tree for each tree felled 	CC	Records review; on site-observation	As needed	GDA	Part of construction supervision cost
<ul style="list-style-type: none"> Confirm location of underground infrastructure Inform public about the likely disruption of services Ensure alternate arrangements during the relocation 	CC & respective agency (BSNL, UJS, GNN)	Observations on- - site; CC records; consult respective agencies; informal public interviews	Weekly	GDA	Part of construction supervision cost
Construction					
<ul style="list-style-type: none"> Utilize surplus soil for beneficial purposes 	CC	Observations on-site/off-site; CC records	Weekly	GDA	Part of construction supervision cost
<ul style="list-style-type: none"> Damp down soil to arrest dust Use tarpaulins to cover soil in transport 					
<ul style="list-style-type: none"> Do not divert/dispose silt laden water into drains Provide temporary ponds in the site Ensure that no water accumulated due to disposal Divert existing drains in the work area (ROW) Construct temporary drains if required Complete construction of new drain early 					
<ul style="list-style-type: none"> Inform local community about the work Identify old and sensitive buildings and safe practices Do not conduct noise generating activities in the night Employ manual methods, where required Avoid noisy or invasive activities in sensitive times; 					

Mitigation measures	Responsible for Mitigation	Monitoring Method & Parameters	Monitoring Frequency	Responsible for monitoring	Cost
<ul style="list-style-type: none"> Utilize modern machinery and in good condition 					
<ul style="list-style-type: none"> Obtained construction material from licensed quarries 					
<ul style="list-style-type: none"> Inform public and business about the work in advance Maintain service roads/pedestrian walks in good condition 					
<ul style="list-style-type: none"> Provide necessary personnel to guide & control traffic Provide bypasses/ traffic detours & inform public Barricade the site properly; avoid accidental entry Provide information to the public through media Provide public information/caution boards at site 	CC	Observations on- - site; CC records; informal public interviews	Weekly	GDA	Part of construction supervision cost
<ul style="list-style-type: none"> Avoid congested/sensitive roads for material transport Avoid peak traffic hours 					
<ul style="list-style-type: none"> Follow standard and safe construction practices Exclude the public from the site and post security guards Provide Personal Protective Equipment to workers Barricade the entire area that may come under influence in case of accidents Follow standard safety checks as prescribed for equipment Employ EHS Expert on site Provide on-site Health and Safety Training for personnel Report accidents and maintain records 					
<ul style="list-style-type: none"> Engage unskilled workforce from local communities 					

8. PUBLIC CONSULTATION AND INFORMATION DISCLOSURE

A. Project Stakeholders

104. Most of the main stakeholders have already been identified and consulted during preparation of this IEE, and any others that are identified during project implementation will be brought into the process in the future. Primary stakeholders are:
- People near the flyover site at Mohan Nagar Junction in Ghaziabad;
 - Public representatives and prominent citizens;
 - Ghaziabad Nagar Nigam;
 - Ghaziabad Development Authority
105. Secondary stakeholders are:
- Other concerned government institutions (utilities, regulators, etc)
 - NGOs and CBOs working in the local area;
 - Other community representatives (prominent citizens, religious leaders, elders, women's groups);
 - The beneficiary community in general
 - NCRPB as the Funding Agency

B. Consultation and Disclosure

106. A series of public consultation meetings were conducted during project preparation. Various forms of public consultations (consultation through household surveys, ad hoc discussions on site) have been used to discuss the project and involve the community in planning the project and mitigation measures.

9. RECOMMENDATION AND CONCLUSION

A. Recommendation

107. The process described in this document has assessed the environmental impacts of the proposed flyover sub-project in Ghaziabad. Potential negative impacts were identified in relation to design, location, construction and operation of the proposed flyover. Mitigation measures have been developed to reduce all negative impacts to acceptable levels. These were discussed with specialists responsible for the engineering aspects, and measures have been included in the designs for the infrastructure. This means that the number of impacts and their significance has already been reduced by amending the design. These include:

- Construction of flyover within the ROW of existing road to avoid the need to acquire land or relocate people
- Design of flyover as per seismic zone to eliminate risk
- Utilizing excavated soil for construction of earthen ramps of the flyover to avoid the need to disposal of surplus soil and as well as creating new borrow areas for filling up soil
- Design of drainage system considering the change in topography
- Compensatory tree plantation – 3 trees for each tree felled
- Avoiding complete closure of road by limiting the construction area to actual flyover site and allowing the traffic on service roads

108. Regardless of these and various other actions taken during the IEE process and in developing the project, there will still be impacts on the environment when the infrastructure is built. This is mainly because clearance of encroachments on ROW; because of the large-scale construction located in a busy urban area. Because of these factors there are impacts on the physical, social and human environment. Following are some of the important mitigation measures suggested:

- Implementation of compensatory measures for clearance of encroachments as recommended by the Resettlement Plan prepared in compliance with NCRPB policies
- Condition that the all compensatory/resettlement measures must be implemented before the signing of contract for civil works

109. During the construction phase, impacts mainly arise from generation of dust from soil excavation and refilling; and from the disturbance of residents, businesses, traffic and important buildings by the construction work. These are common impacts of construction in urban areas, and there are well developed methods for their mitigation. Among these, public and worker safety due to large scale construction using heavy-duty construction equipment, traffic disturbance during construction is considered to be significant. Important measures suggested include:

- Dust control measures such as water sprinkling and covering the loose material during transport
 - Proper planning and scheduling of noise generating activities
 - Maintaining service roads and pedestrian walks in good condition and provision of personnel to guide traffic
 - Providing alternative traffic routes/detours and informing public about the same
 - Providing public information boards at site (project details, traffic arrangements, executing agency and contractor details; safety and contact information)
 - Following standard and safe construction practices (barricading the site properly; avoiding accidental traffic entry including pedestrians; deployment of safety and security staff; providing warning/sign boards; provision of protection equipment; special precautions during risky works like arranging the pre-cast elements and equipment safety checks, etc)
110. Once the construction is over, the flyover will function without any major maintenance so no major impacts envisaged.
111. The main beneficiaries of the flyover project will be will be the citizens of Ghaziabad and road users in general.
112. Mitigation will be assured by a program of environmental monitoring conducted to ensure that all measures are provided as intended, and to determine whether the environment is protected as envisaged. This will include observations on and off site, document checks, and interviews with workers and beneficiaries, and any requirements for remedial action will be reported to the NCRPB.
113. Stakeholders were involved in developing the IEE through both face-to-face discussions on site and a large public meeting will be held in the town, after which views expressed will be incorporated into the IEE and the planning and development of the project.
114. There are two essential recommendations that need to be followed to ensure that the environmental impacts of the project are successfully mitigated. The IA shall ensure that:
- All mitigation, compensation and enhancement measures proposed in this IEE report and in the Resettlement Plan (RP) of the subproject are implemented in full, as described in these two documents;
 - The Environmental Monitoring Plan proposed in this report and the internal and external monitoring proposed in the Resettlement Plan are also implemented in full.

B. Conclusion

115. The environmental impacts of the proposed flyover subproject in Ghaziabad have been assessed by the Initial Environmental Examination reported in this document, conducted according to the NCRPB ESMS. Issues related to Involuntary Resettlement were assessed by a parallel process of resettlement planning and will be compensated by measures set out in detail in the Resettlement Framework for the subproject.
116. The overall conclusion of both processes is that providing the mitigation, compensation and enhancement measures are implemented in full, there should be no significant negative environmental impacts as a result of location, design, construction or operation of the subproject.
117. There are no uncertainties in the analysis, and no additional work is required to comply with NCRPB procedure or national law. There is thus no need for further study or Environmental Assessment.

www.WilburSmith.com

WilburSmith
A S S O C I A T E S

#8, Second Floor, 80 Feet Road,
RT Nagar Bangalore Karnataka - 560 032. India
w +91.80. 3918.7500 f +91.80. 2363.4097